



BUILDING CONTROL INFORMATION SHEET



Loft Conversions

FIRE SAFETY

Existing bungalows

Where a loft conversion results in a two-storey dwelling additional fire precautions are required. These consist of the provision of windows suitable for means of escape at first floor level in habitable rooms. In addition to this, mains operated smoke detectors should be provided at each level.

Existing two storey dwellings

Where forming additional room(s) in the roof space of an existing two-storey dwelling, thereby creating a three-storey dwelling, additional structural fire precautions and means of escape requirements apply. These requirements are necessary due to the greater height from ground level, the resulting increase in travel distance to exit the building and the increased delay in becoming aware of a fire on the ground floor. Additional requirements include ½ hour fire resisting construction to stairwell including fire doors to all rooms except toilets and bathrooms. The existing stairs should not discharge directly into an open plan lounge, kitchen or other habitable room. The provision of mains powered smoke detectors is also required.

STRUCTURE

- **Existing** – Where the existing roof structure is to be altered i.e. removal of purlins and struts or internal roof truss members, the roof must continue to be adequately supported usually via load-bearing studwork onto load-bearing elements such as internal walls or new steel beams. To ensure that the existing structure is suitable for carrying additional loads, it may be necessary to dig trial holes to check the existing foundations to internal and external walls, and it may be that existing lintels will need to be replaced.
- **Floor** – It is unlikely that the existing ceiling joists will be adequate for the new floor loading and new joists will need to be inserted (these may be laid between the existing joists). Their size will be dependant upon the spans involved and if supporting additional loads such as the roof / stud walls then calculations will be required.
- **Dormers** – The dormer construction must include a suitable head beam over the window supported off posts at either side. The posts must be supported on load-bearing elements such as existing walls or new steel beams. The sidewalls of the dormer (dormer 'cheeks') are usually built off double joists / rafters. You must ensure that the size and location of dormers do not affect the overall stability of the roof structure.

THERMAL INSULATION / ROOF VENTILATION

The new room in the roof should have adequate thermal insulation in accordance with current Building Regulations. This can be achieved in a manner of different ways. As a result of providing insulation into the sloping sections of a roof, adequate cross-flow ventilation must be achieved to avoid the risk of condensation and a vapour control layer is also required (e.g. foil-backed plasterboard) unless the roof has a breathable membrane.

SOUND INSULATION

Sound insulation should be provided using a minimum thickness of 100mm of mineral wool having a minimum density of 10kg/m³, laid between the new floor joists. The floor covering must have a minimum mass per unit area of 15kg/m² which would be achieved using 22mm tongued and grooved chipboard flooring.





STAIRS:

A minimum stair width of 800mm is recommended. Headroom, vertically above the pitch line 2 metres. Max. rise per step 220mm, minimum going 220mm, with max pitch 42°. A handrail must be fitted 900 to 1000mm above the pitch line of the stairs or the floor of any landing, fitted with vertical rails. If tapered (winder or kite) or unusual staircase designs are proposed please consult a Building Control Surveyor to clarify requirements.



VENTILATION

New windows must be double glazed and meet current standards for U-Value requirements.



For ventilation purposes the opening area must amount to a minimum 1/20 of the floor area of the room served and background ventilation by way of trickle ventilation is required, a minimum of 8000mm² for habitable rooms, 4000mm² for bathrooms. It should be noted that bathrooms and shower rooms also require mechanical ventilation to the external air at a minimum rate of 15 litres/second.

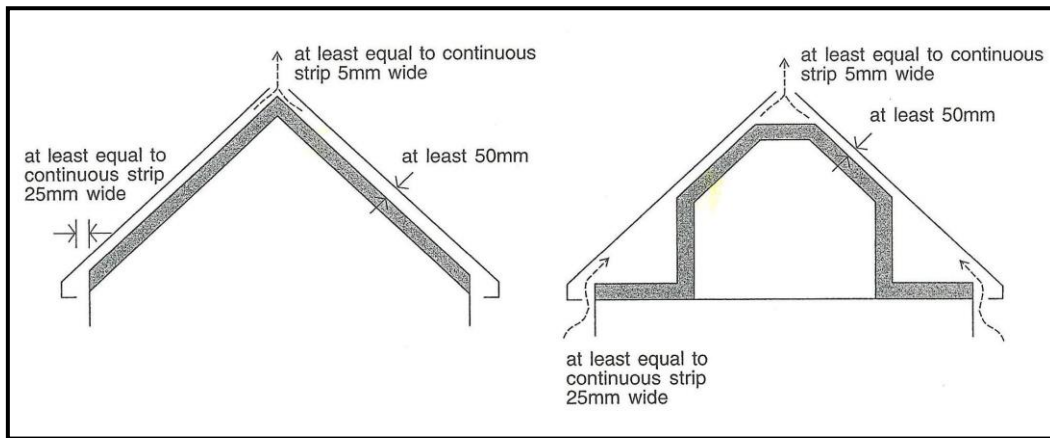

Note: Where escape windows for bungalow loft conversions are required they must achieve an unobstructed openable area of at least 0.33m² and be at least 450mm wide, a minimum of 450mm high and situated not more than 1.7m from the edge of the roof, measured along the slope.



ELECTRICS:

The electrical installation should be carried out by a competent person belonging to a Government scheme, or it will be necessary for you to pay us an additional fee. Please refer to our leaflet on 'Electrical Safety' for further information.



NOTE:

These notes are applicable to domestic property only. They are for guidance only and are not intended to be a comprehensive list of the requirements. There may be alternative ways to meet the requirements of the Building Regulations and these should be discussed with the Area Building Control Surveyor.



For information concerning Planning Permission please contact Development Control on (01983) 823552.



Building Control, Seaclose Offices, Fairlee Road, Newport, Isle of Wight, PO30 2QS

Telephone: (01983) 823580

E-mail: building.control@iow.gov.uk

Website: www.iwight.com/buildingcontrol



(Oct 2018)

